

Ruelco



SS-H Hydraulic Pressure Switch Hi Model 4HH2

Phone (504) 340-0055
Fax (504) 340-0056

SS-H

Hydraulic Pressure Switch Hi Model 4HH2

Parts List For Pressure Switch Model 4HH2

Item	Qty.	Description	Material	Part No.
1	1	Spring Cap	316L or ASTM-A-351 S.S.	41-009-0A0
2A	1	Spring (Blue)	ASTM-401	41-012-000
2B	---	Spring (Red)	ASTM-401	41-013-000
2C	---	Spring (Silver)	ASTM-401	41-014-000
2D	---	Spring (Green) Optional	Inconel X-750	41-019-000
2E	---	Spring (Yellow) Optional	Inconel X-750	41-020-000
2F	---	Spring (Purple) Optional	Inconel X-750	41-021-000
3	1	Parts Tube	Acetate Butyrate	42-025-000
4	1	Lock Ring	AISI 316 St. Stl.	41-015-000
5	1	Panel Mount Ring (Optional)	AISI 316 St. Stl.	41-023-000
6	1	Spring Plate	AISI 316 St. Stl.	41-008-0A0
7*	3	Spool O-Ring	Buna-N	NO-008-75
8	1	Top Sleeve	AISI 316 St. Stl.	4H-002-000
9*	2	Top Sleeve O-Ring	Buna-N	NO-014-75
10	1	Body	AISI 316 St. Stl.	4H-001-0H0
11*	2	Bottom Sleeve O-Ring	Buna-N	NO-014-75
12*	1	Backup	Teflon	TB-008-000
13	1	Bottom Sleeve	AISI 316 St. Stl.	4H-003-000
14	1	Spool	AISI 316 St. Stl.	4H-004-0H0
15	1	1.25" / .50" Piston	AISI 316 St. Stl.	42-005-000
16	1	1.25" / .50" / .25" Sensor Base	AISI 316 St. Stl.	41-004-0A0
17*	1	O-Ring F/ 1.25" Piston	Viton	VO-024-75T
18*	1	O-Ring F/ .5" Piston	Viton	VO-012-75T
19	1	.25" Piston (Optional)	AISI 316 St. Stl.	41-011-0A0
20*	1	Backup F/ .25" Piston	Teflon	TB-006-0B0
21*	1	O-Ring F/ .25" Piston	Viton	VO-006-75T
22	1	Repair Kit	* Items	4H-005-0B0

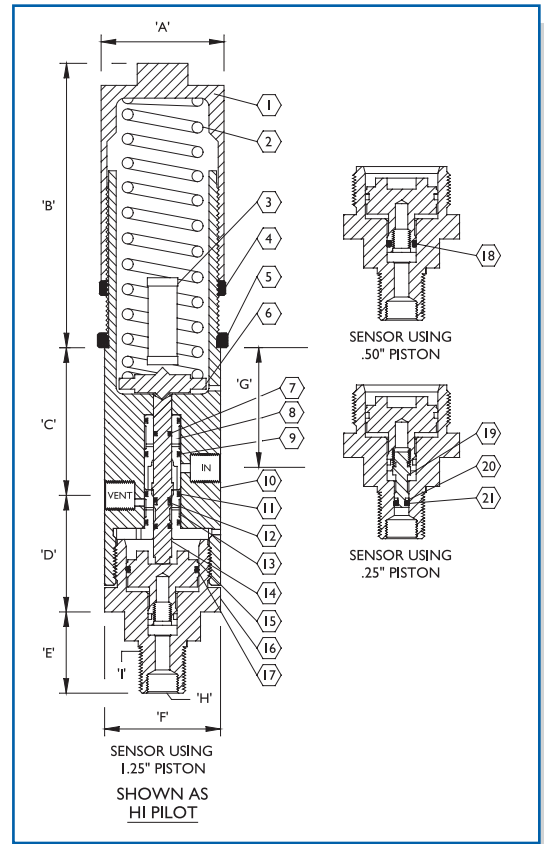

Dimensions Inch (MM)

A	2.12 (53.8)
B (Max)	6.13 (155.7)
C	1.55 (39.4)
D	3.00 (76.2)
E	1.40 (35.6)
F	2.00 (50.8)
G	2.08 (52.8)
H	1/4" FNPT
I	1/2" MNPT
Panel Mount Hole	1.875 (48.0)
Valve Ports	1/4" FNPT
Weight*	4.9 lbs (2.3 kg)

* For switch and 1.25"/.50"/.25" sensor base

Switch Specifications

Valve Type	2-Way
Setpoint Deviation	+ 3%
Max. Instr. Press.	6,000 PSI (414 BAR)
Ambient Temp. Range	20 to 250 deg. F -29 to 122 deg. C
C _v Factor	.12

1.25"/.50"/.25" Switch Sensor Specifications

Sensor Type	Piston
Max. Oper. Press.	10,000 PSI (690 BAR)
Burst Pressure	20,000 PSI (1380 BAR)
Temperature Range	-20 to 250 deg. F -29 to 122 deg. C

Ordering Code: 4HH2 X X X 0 0 0

BASE MODEL NUMBER

Standard Corrosive Service - (-)
N.A.C.E. Option - N

SPRING CODE (see range chart)

PISTON CODE (see range chart)

Spring Codes (COLOR)		Available Ranges - PSI (BAR)														
		5-20 (.03-1.4)	4-40 (.3-2.75)	10-80 (.7-5.5)	10-115 (.7-7.9)	20-230 (1.4 - 15.8)	50-450 (3.4 - 31)	200-750 (13.8-51.8)	500-1500 (34.5-103.5)	1000-3000 (69-207)	1000-3000 (69-207)	2000-5000 (138-345)	5000-10000 (345-689)	2000-5000 (138-345)	3500-9000 (241-620)	8500-20000 (586-1380)
STANDARD SPRING	INCONEL SPRING	X			X			X		X				X		
B (Blue)	G (Green)		X			X			X						X	
R (Red)	Y (Yellow)			X			X			X						X
S (Silver)	P (Purple)				X			X		X		X				X
Piston Diameter		3.0"	3.0"	3.0"	1.25"	1.25"	1.25"	.50"	.50"	.50"	.25"	.25"	.25"	.187"	.187"	.187"
Piston Code		0	0	0	1	1	1	2	2	2	3	3	3	4	4	4
		OPTIONAL BASE					OPTIONAL PISTON					OPTIONAL BASE				

While this information is presented in good faith and believed to be accurate, Ruelco, Inc. does not guarantee satisfactory results from reliance upon such information. Nothing contained herein is to be construed as a warranty or guarantee, expressed or implied, regarding the performance, merchantability, and fitness with respect to the products. Ruelco, Inc. reserves the right, without notice, to alter or improve the designs or specifications of the products described herein.