

Function

The Ruelco Self-Contained System is designed for the automatic closing of hydraulic actuators operating in various conditions, when external power sources are unavailable. The system allows the operator to easily and reliably open the well control actuator, and ensure that the system is functioning properly. The low and high pressure accumulators will maintain system pressure through temperature fluctuations. The integrated pressure switches allow for precise high and low pressure control of the flow line, and will automatically act to shut down the actuator.



Design Features

- Manifold design with no external tubing on the unit reduces leak points as well as reduces likelihood of damage at jobsite.
- All material is NACE rated using anodized 6061-T6 aluminum and 316 stainless steel.
- Low and high pressure relief valves preset to desired pressure to prevent damage to actuator or low pressure equipment.
- Quick Exhaust for fast response time
- Solenoid operated control (50 psi Max)
- 40 micron suction filter and magnetic drain plug to prevent contamination of the system.
- Stainless steel gauges with dual scales.
- Integrated pressure switches allow for flow line control without additional components and reduce the tubing required for install.
- Seal material used allows full functionality from -50° F to 180° F (Optional seal materials available upon request).
- High and low pressure accumulator accommodates for thermal expansion volume changes.
- System is easily charged with use of red anodized latch.
- Sight glass on tank allows for visual level indication of system.
- Check valve in suction tube ensures a constant prime of the pump.

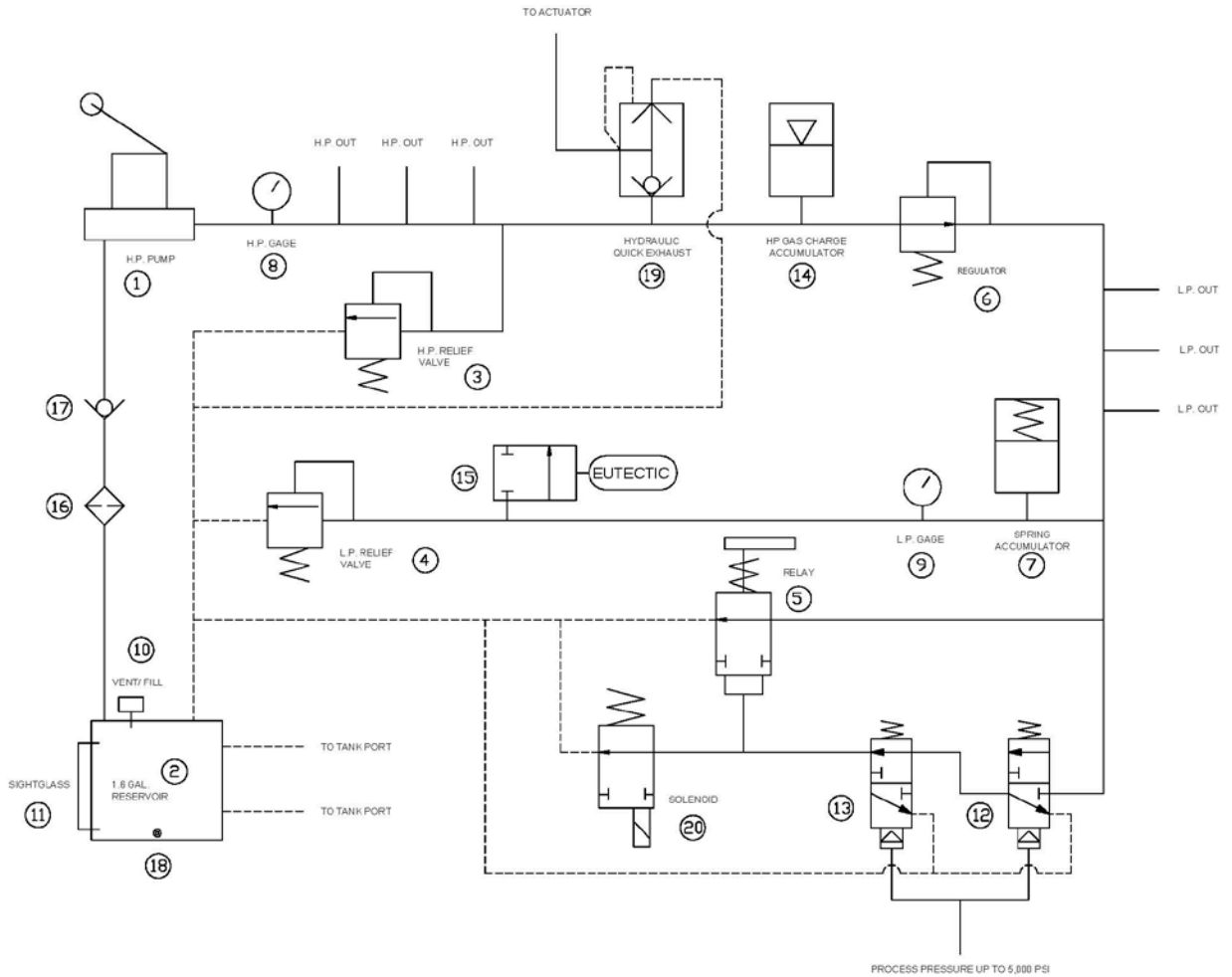

- | | |
|-----------------------------------|---------------------------------------|
| ① High Pressure Hand Pump | ⑪ Sight Glass |
| ② 1.6 Gallon Aluminum Reservoir | ⑫ Low Pressure Switch |
| ③ High Pressure Relief Valve | ⑬ High Pressure Switch |
| ④ Low Pressure Relief Valve | ⑭ HP Gas Charge Accumulator |
| ⑤ Manual Reset Relay | ⑮ Fuse Plug |
| ⑥ Regulator | ⑯ 40 Micron Filter |
| ⑦ 4.8 cu in LP Spring Accumulator | ⑰ Suction Check Valve |
| ⑧ 0 - 5,000 psi Gage | ⑱ Magnetic Drain Plug |
| ⑨ 0 - 60 psi Gage (Standard) | ⑲ Quick Exhaust |
| ⑩ Vent/ Fill Cap | ⑳ Solenoid Operator (12VDC or 24 VDC) |

Specifications

Temperature	Range	-50 F to 180 F
HP Circuit	Max Pressure	5,000 psi
LP Circuit	Max Pressure	120 psi
	Min Pressure	30 psi
LP Relief Valve	Range	50-150 psi
HP Relief Valve	Range	2,000 - 6,000 psi
	Range (Optional)	250 - 3,000 psi
Reservoir	Capacity	1.6 gallons
	Capacity (Optional)	2.5 gallons
LP Accumulator	Capacity	4.8 cu in
HP Accumulator	Capacity	6 cu in
	Capacity (Optional)	16 cu in
Solenoid Normally Open	Voltage	12VDC or 24 VDC
	Wattage	1.8 watts
	Rating	Class 1 Div 1 A,B,C,D NEMA 4
	Max Pressure	50 psi
Pump	Displacement	.39 cu in/ stroke
Fuse Plug	Temperature Range	158°F to 283°F
Pressure Switch	Repeatability	1%
	Deadband	8%
	Cv	.13
	Max Process WP	5,000 psi
	Max Process WP (Optional)	10,000 psi (316 Only)
	Burst Pressure	5,000 psi
	Burst Pressure (Optional)	10,000 psi (316 Only)
	Standard Ranges	1G (50 - 200 psi)
		1Y (175 - 450 psi)
		2G (450 - 1,750 psi)
		2Y (1,500 - 3,000 psi)
	High Pressure	2P (2,000 - 5,000 psi)
		2S (4,500 - 10,000 psi)

Installation

Every Ruelco Self-Contained unit is 100% function tested using a fully charged gas accumulator. After testing, the gas accumulator is fully discharged and the each unit is shipped with a clean and empty tank.

NOTE: The gas charge accumulator must be pre-charged at the time of commissioning at the operating temperature for proper function of the unit. Ruelco can recommend a pre-charge and operating pressure based upon the actuator minimum hold open pressure, maximum actuator pressure, and the environmental conditions. For actuator volumes/ systems over 150 cu in, Ruelco recommends using the 16 cu in option in order to optimize the functional temperature range of the unit. Charge kits are available P/N: 20-205-000.

Ruelco recommends using Shell Aero 41 or equivalent.

Connections

Only two connection lines are necessary to install and operate the unit.

1. Connect the actuator to one of the three high pressure outlet ports on the manifold or if installed, the "To Actuator" port of the quick exhaust.
2. Connect the process flow line to the back of the pressure switch manifold.

Gas Charge Accumulator Charging Procedure

1. Remove Gas Valve Guard from top of the Accumulator then remove the yellow gas valve stem cap.
2. Using the two $\frac{3}{4}$ " open-ended wrenches, open the accumulator gas valve by turning the top hex clockwise.
3. Connect charging gooseneck fitting to a nitrogen tank with a pressure gauge in line.
4. Connect the swivel nut on the gooseneck fitting to the gas valve.
5. Slowly open nitrogen supply valves until in line pressure gauge reads required pressure.
6. Using the two $\frac{3}{4}$ " open-ended wrenches, completely close the accumulator gas valve by turning the bottom hex counterclockwise.
7. Close all valves leading to the nitrogen supply tank. Vent any nitrogen that remains in the lines.
8. Remove the accumulator from the swivel nut on gooseneck fitting.
9. Install the yellow gas valve stem cap, and then reinstall the gas valve guard.

Operation

For maximum performance and system life, prior to connecting the system to the actuator, ensure that the actuator and connecting tubing is fully flushed and cleaned. This will prevent debris from entering the system through the actuator when draining as well as prevent mixing hydraulic oils or other fluids within the system. The unit is shipped dry and is tested using clean and filtered hydraulic oil.

Prior to operating the system, ensure that the low pressure and high pressure relief valves are set to the needs of the actuator.

Flowline pressure should be connected to the ¼" npt port on the pressure switch base.

Ruelco recommends that prior to ordering the unit; the information on page 10 "Self-Contained Parameters" is completed. This will allow Ruelco to recommend set points for the relief valves and operating conditions for the unit. Proper set points will allow the unit to better function in the desired environment for extended periods of time.

Start-up Manual Mode

1. Lift the latch handle into the horizontal position.
2. Stroke the pump until the desired low pressure output is obtained. The low pressure circuit is preset to 30 psi via the regulator.

Note: If the flow line pressure is between the high and low set points of the pressure switches, the latch will fall into an armed position. If the flow line pressure is out of the pressure switch set points, the latch will remain in the "Manual" position. If this occurs, the system is not in "Automatic mode" and can only be shutdown manually.

3. Continue to stroke the pump until the actuator is fully opened.
4. The latch should be in the armed hanging position indicating that the system is in the "Set" state.
5. Ruelco recommends that the pump handle be left in the upward position to prevent any high pressure leakage, causing slow bleed down of the system.

Shutdown

High or Low Pressure

The system will automatically shut down if the flowline pressure deviates outside of the pressure switch set points. The pressure switches are independently adjustable for both high and low pressure control, by screwing in or out the adjustment plug. The ranges can also be easily changed by changing the

springs or piston seals. Once the flow line pressure rises or falls outside the parameters set by the pressure switches, the pilot signal holding the latch handle will vent and shut down the system. The latch handle will return to the downward locked state.

Fuse Plug

A fuse plug comes installed in the low pressure outlet port of the regulator and will vent the low pressure hydraulic signal, if fire activated. The fuse plug can be set to a variety of temperatures ranging from 158° F to 350° F. The fuse plug will have to be replaced after use.

Manual Push Relay

The relay latch can be pushed inward, manually venting the pilot control signal. This will shut down the low pressure and high pressure circuit, closing the connected actuator.

Solenoid

An integrated manifold mounted solenoid valve can be used as a remote operated shutdown. The normally open solenoid is mounted to the relay and will vent the pilot signal upon loss of an electric signal. This will shift the relay and shut down the system. The solenoid is available in a 12VDC or 24VDC option.

ESD Valve (Not Included)

An optional external ESD valve can be connected to the low pressure output on the manifold. If this valve is activated manually, the low pressure signal will be lost and the shut down the system.

Spare Parts/ Repair List

<u>Description</u>	<u>Part Number</u>	<u>Qty Required</u>
Regulator	5001-05000	1
LP Spring Accumulator	5002-05000	1
Relay	5003-05000	1
Pressure Switch	5004-XXXX0	1
Quick Exhaust	5005-05000	1
Solenoid Valve	5003-S5000	1
Fuse Plug	2102-25XXX	1
HP Gas Charge Accumulator	2400-L5000	1
HP Relief Valve	7500-2R000	1
LP Relief Valve	SC-055-000	1
Magnetic Drain Plug	SC-070-000	1
Pump w/ SS Shaft	SC-071-00S	1
40 Micron Filter	SC-024-040	1
Suction Check Valve	SC-023-000	1
Reservoir	50-003-000	1
Sight Glass	SC-077-000	1
0-60 psi Gauge	SC-075-060	1
0-5000 psi Gauge	SC-076-000	1
Handle	SC-072-000	1
Mounting Bracket	50-100-000	1
Repair Kit f/ Regulator	SC-044-000	1
Repair Kit f/ LP Spring Accumulator	SC-013-000	1
Repair Kit f/ Relay	SC-016-000	1
Repair Kit f/ Pressure Switches	50-015-000	1
Repair Kit f/ HP Gas Charge Accumulator	20-204-000	1
Repair Kit f/ HP Relief Valve	75-015-000	1
Repair Kit f/ Quick Exhaust	50-047-000	1
Repair Kit f/ Solenoid Valve	50-064-000	1
Repair Kit f/ LP Relief Valve	SC-054-000	1
Repair Kit f/ Pump	SC-021-000	1
Repair Kit f/ Sight Glass	SC-065-000	1
Tank Gasket	SC-022-000	1
Gas Charge Kit	20-205-000	1

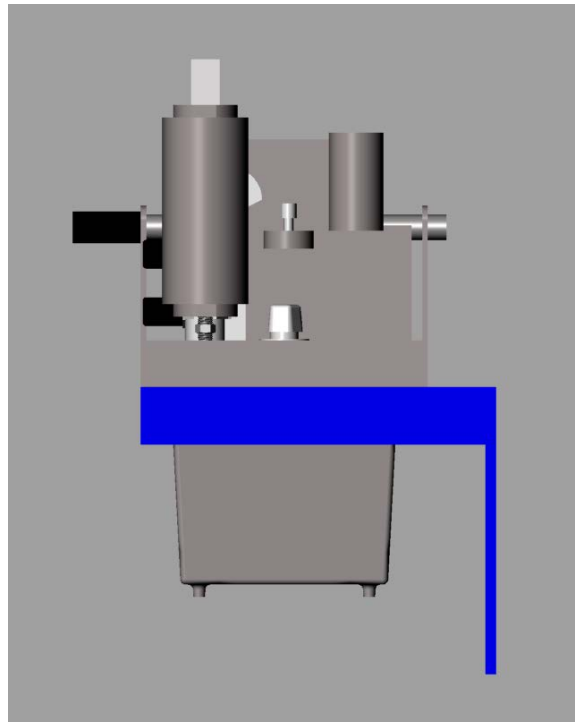

Side View of Bracket

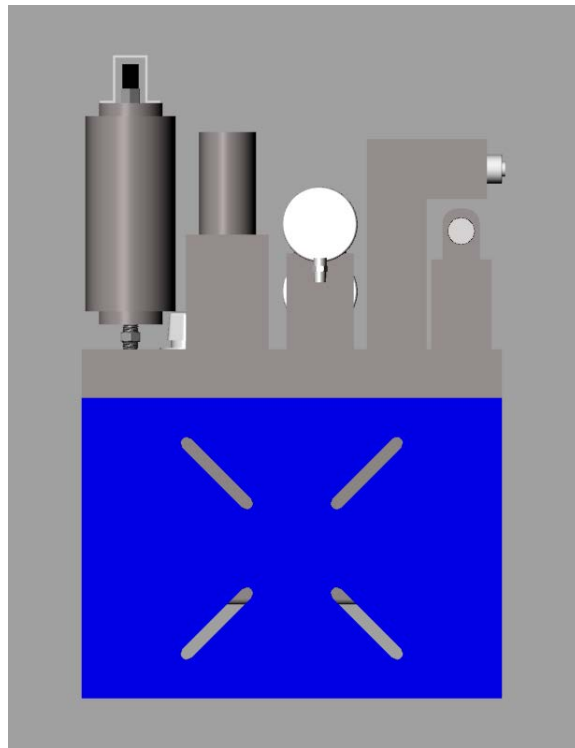

Back View of 3" -7" Square Mounting Slots



Title: Ruelco Self-Contained Parameters	Author: Griff Poindexter Date:
--	--------------------------------------

Customer Name:
Inquiry Date:

Actuator Information

Actuator Volume= cu.in.
Max Actuator Pressure= psi
Minimum Actuator Hold Open Pressure= psi

Ruelco Self-Contained Operating Parameters

Accumulator Size=	<input type="text" value="6"/>	cu.in.	Standard
High Pressure Relief Valve Set Point=	<input type="text"/>	psi	Ruelco Recommended Based Upon Actuator Data
Low Pressure Relief Valve Set Point=	<input type="text" value="50"/>	psi	Standard
Regulator Set Point=	<input type="text" value="30"/>	psi	Standard
High Pressure Accumulator Pre-charge=	<input type="text"/>	psi	Calculation based on temperature performance
High Pressure Switch Set Point=	<input type="text"/>	psi	Customer Provided (if applicable)
Low Pressure Switch Set Point=	<input type="text"/>	psi	Customer Provided (if applicable)

TROUBLESHOOTING

<u>Trouble</u>	<u>Possible Causes</u>	<u>Corrective Repair Instructions</u>
Cannot Charge System	<ol style="list-style-type: none"> 1. Low Oil Level 2. No Power to Solenoid 3. Clogged Filter 4. Process Pressure out of Range 5. Stuck Check Valve 	<ul style="list-style-type: none"> - Fill with oil until above minimum level - Check solenoid connections - Remove Tank and clean filter - Check that process pressure is in between Pressure switch Set Points - Remove Pump and lightly depress suction check ball
Losing System Pressure	<ol style="list-style-type: none"> 1. Hydraulic leak in external lines 2. Pressure Switch tripped High or Low 3. Thermal expansion 4. Low Pressure Leaks 5. Low Pressure Rises 6. High Pressure Leaks 	<ul style="list-style-type: none"> - Check all fitting connections - Check sense pressure gauge and adjust set points if needed - Check HP accumulator pre-charge is set correctly - Check HP relief valve is set sufficiently above the max anticipated control pressure - Check that low set pressure is above 25 psi (minimum to hold relay open) - Check LP relief valve is set sufficiently above the low pressure control circuit - Clean Regulator /Change Seat - Make sure pump handle is in the upward position - Ensure proper torque on Pump 45 ft*lbs