

## OPERATION

The Ruelco EX-1 quick exhaust is designed to rapidly vent the control pressure from an actuator or other pneumatic device. It is typically used on safety valves, control valves, or other devices that must quickly respond when the control signals are removed. Its in-line design and three part construction make the quick exhaust easy to install and maintain. No special tools are needed for repair and assembly. The Ruelco EX-1 will improve equipment operation and reduce maintenance time.

## FEATURES

- 316 stainless steel construction (models to N.A.C.E. MR0175 available)
- Durable polyurethane or fluorocarbon seal
- Large Cv factors produces large flow rates
- Small compact design
- No moving parts

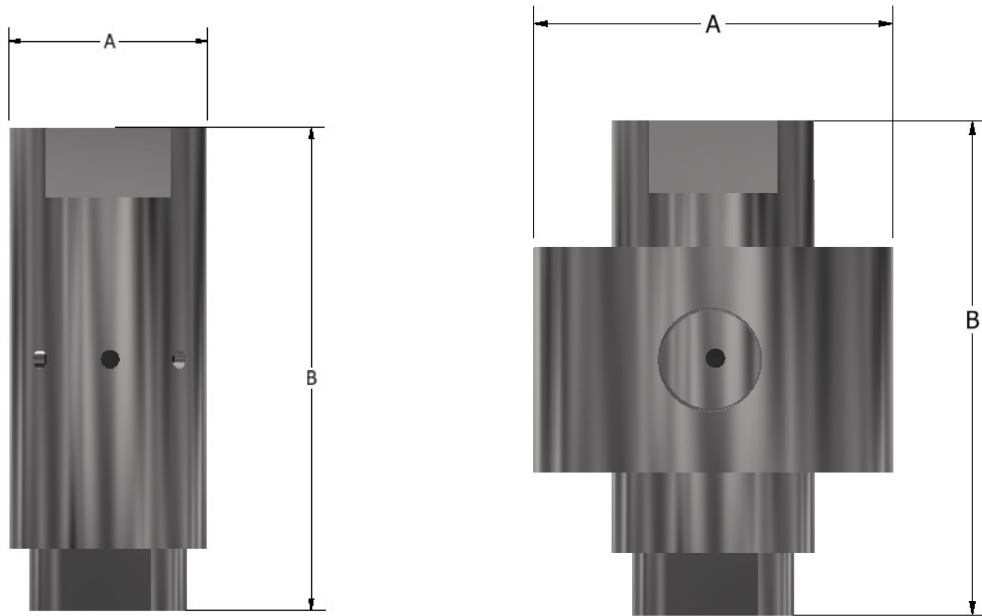

SHOWN WITH OPTIONAL EXHAUST PORT

## DIMENSIONS

A	.875" (22.1 mm)
A (WITH OPTIONAL EXHAUST PORT)	2.00" (50.8 mm)
B	2.80" (71.1 mm)
INLET AND OUTLET PORT SIZE	1/4" FNPT
OPTIONAL EXHAUST PORT	3/8" FNPT
WEIGHT	12.0 OZ (227 gm)

PHONE: 504-340-0055  
FAX: 504-340-0056  
EMAIL: SALES@RUELCO.COM

1209 DISTRIBUTORS ROW  
NEW ORLEANS, LA 70123

PNEUMATIC QUICK EXHAUST

## PARTS LIST

ITEM	QUANTITY	DESCRIPTION	MATERIAL
1	1	CENTER SPOOL	316 ST. STL.
2*	1	BLADDER	POLYURETHANE OR FLUOROCARBON
3A	1	BODY - STANDARD	316 ST. STL.
3B	-	BODY – 500 PSI	316 ST. STL.
4	1	THREADED EXHAUST PORT BODY	316 ST. STL.
5	1	SET SCREW	316 ST. STL.
6#	2	EXHAUST PORT SEAL	FLUOROCARBON

\* INDICATES ITEMS IN THE STANDARD REPAIR KIT

# INDICATES ADDITIONAL ITEMS IN THE OPTIONAL REPAIR KIT

## SPECIFICATIONS

MAXIMUM WORKING PRESSURE	150 PSI (10.3 BAR)
HIGH PRESSURE BODY MAXIMUM WORKING PRESSURE	500 PSI (34.5 BAR)
POLYURETHANE BLADDER AMBIENT TEMPERATURE RANGE	-40 TO 180° F -40 TO 82° c
VITON BLADDER AMBIENT TEMPERATURE RANGE	-20 TO 250° F -29 TO 122° C
Cv FACTOR VENTING	2.75
Cv FACTOR INPUT	1.0

## REPAIR KIT

- 17-004-000
- 17-006-000 WITH OPTIONAL EXHAUST PORT

OTHER TEMPERATURE RANGES AND SEAL COMPOUNDS AVAILABLE UPON REQUEST

## ORDERING CODE

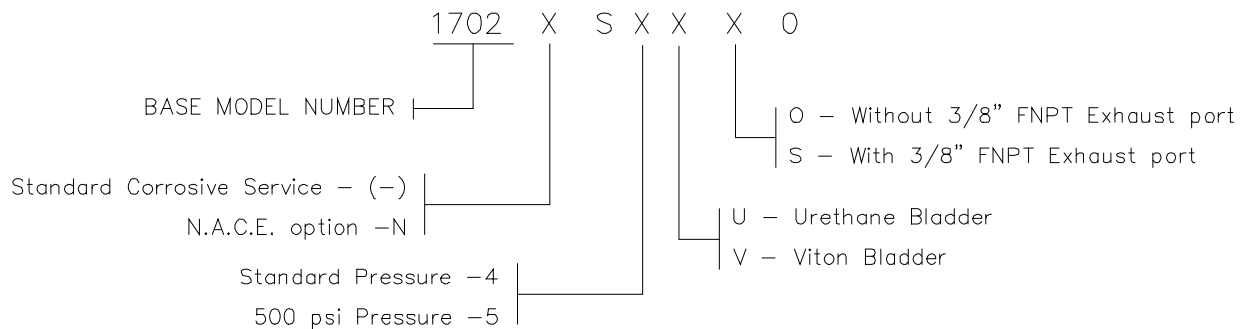

PHONE: 504-340-0055  
 FAX: 504-340-0056  
 EMAIL: SALES@RUELCO.COM

1209 DISTRIBUTORS ROW  
 NEW ORLEANS, LA 70123