

## OPERATION

The Ruelco SC-1 Interface Valve is a normally closed, 3-way, block then bleed hydraulic controller, which will completely isolate all three ports in the final movement of its function. The valve will allow inlet to outlet communication when a pilot supply is present. The unique aspect of the valve is that when the pilot supply is completely removed, the valve will prevent the outlet port from communicating with the vent port. This is extremely useful in preventing a leaking SCSSV from free flowing into the surface WHCP. While the pilot supply is present the valve functions as a normal interface valve allowing the user to control pressures as high as 10,000 psi with a pilot supply pressure of 100 psi. As the pilot supply is removed, the outlet pressure is vented, allowing the SCSSV time to close, before isolating the outlet from the vent port.

## FEATURES

- 316 stainless steel construction (models to N.A.C.E. MR0175 available)
- Large Cv factor assures fast system response
- All soft seal design
- Design minimizes malfunctions due to supply system debris
- Built rugged for years of reliable field service

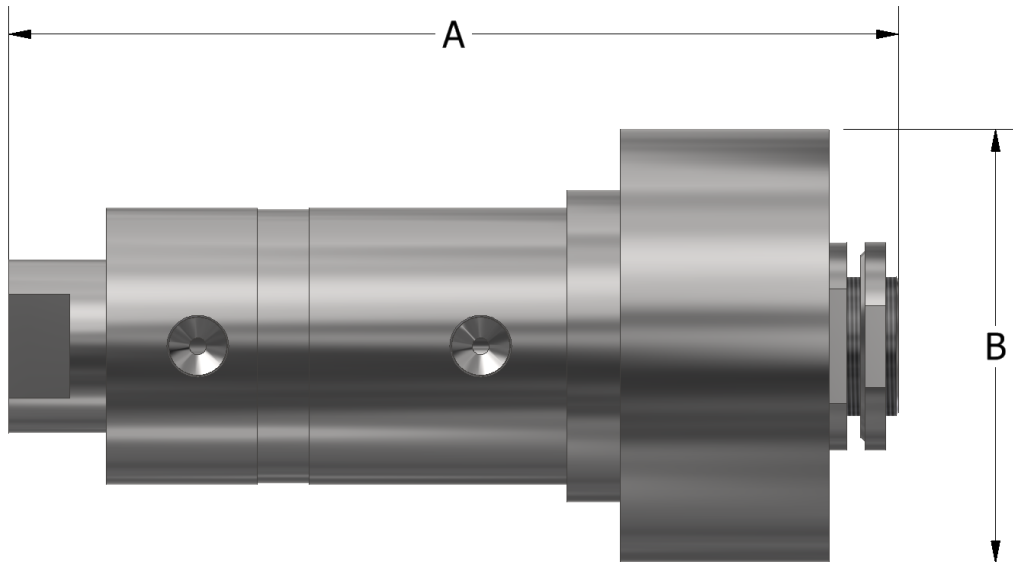

## DIMENSIONS

A	6.42" (163.1 mm)
B	3.125" (79.4 mm)
PANEL MOUNT HOLE	1.0" (25.4 mm)
HYDRAULIC CONNECTION PORTS	1/4" FNPT
PILOT CONNECTION PORT	1/4" FNPT
WEIGHT	5.1 lbs (2.31 KG)

PHONE: 504-340-0055  
 FAX: 504-340-0056  
 EMAIL: SALES@RUELCO.COM

1209 DISTRIBUTORS ROW  
 NEW ORLEANS, LA 70123

## SPECIFICATIONS

MAXIMUM INSTRUMENT PRESSURE	200 PSI (13.8 BAR)
MAXIMUM WORKING PRESSURE	10,000 PSI (680 BAR)
BURST PRESSURE	20,000 PSI (1380 BAR)
OUTLET ORIFICE SIZE	.125" (3.18 mm)
AMBIENT TEMPERATURE RANGE	-20° TO 250° F -20° TO 122° C

## REPAIR KIT

- 82-009-000

OTHER TEMPERATURE RANGES  
AND SEAL COMPOUNDS AVAILABLE  
UPON REQUEST

## CONTROL PRESSURE CHART

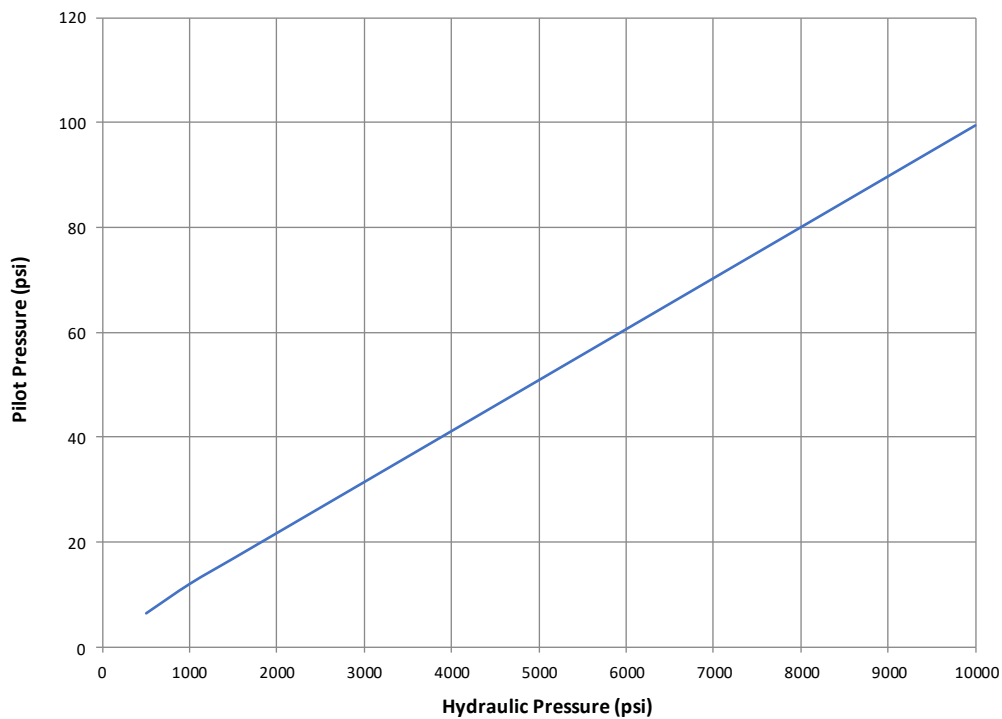

SC-1 3-WAY HYDRAULIC CONTROLLER

PHONE: 504-340-0055  
FAX: 504-340-0056  
EMAIL: SALES@RUELCO.COM

1209 DISTRIBUTORS ROW  
NEW ORLEANS, LA 70123

## PARTS LIST

ITEM	QUANTITY	DESCRIPTION	MATERIAL
1	1	PANEL MOUNT NUT	316 ST. STL.
2	1	CAP	316 ST. STL.
3*	1	PISTON SEAL	FLUOROCARBON
4	1	SPOOL ASSEMBLY	17-4 ST. STL. & 316 ST. STL.
5	1	PISTON SPRING	316 ST. STL.
6	1	BODY	316 ST. STL.
7*	1	SPOOL BACK-UP SEAL	TEFLON
8*	1	SPOOL SEAL	NITRILE
9*	1	SHAFT SEAL	FLUOROMYTE
10*	1	SHAFT SEAL BACKUP	PEEK
11*	2	SLEEVE BACK-UP SEAL	TEFLON
12*	2	SLEEVE SEAL	NITRILE
13	1	TOP SLEEVE	316 ST. STL.
14*	1	BLOCK SEAL	PEEK
15	1	SHUT OFF SLEEVE	316 ST. STL.
16	1	SHUT OFF PISTON	17-4 ST. STL.
17	1	SHUT OFF SPRING	316 ST. STL.
18*	1	BALL SEAL	PEEK
19*	1	BALL	TUNGSTEN CARBIDE
20	1	BOTTOM SLEEVE	316 ST. STL.
21	1	SPRING	316 ST. STL.
22*	1	BOTTOM CAP SEAL	NITRILE
23	1	BOTTOM CAP	316 ST. STL.

\*Indicates item(s) contained in the Repair Kit

## ORDERING CODE

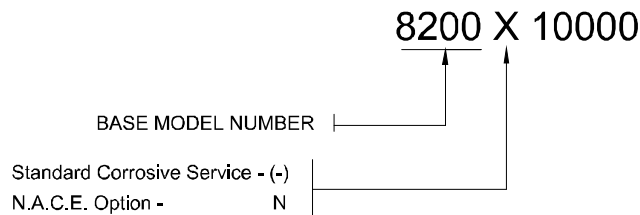

PHONE: 504-340-0055  
 FAX: 504-340-0056  
 EMAIL: SALES@RUELCO.COM

1209 DISTRIBUTORS ROW  
 NEW ORLEANS, LA 70123