

OPERATION

The Ruelco Sand Probe is designed to work with the Ruelco Sand Probe Relay to provide a positive indication of excessive erosion or corrosion which can occur in flow line pipes due to sand or other foreign debris. The thin wall probe will wear due to the constant presence of sand and activate the relay once pressure integrity has been lost. This will alert field personnel to possible inspection and repair needs. The probe is designed to wear 5 times faster than the flow line it is protecting and is pressure rated to 1.25 times the pipe it is installed into.

FEATURES

- Stock probes available in 316 stainless steel and 1018 carbon steel
- Exotic Materials available
- Temperature Range -50°F to 450°F
- Custom wall thicknesses available

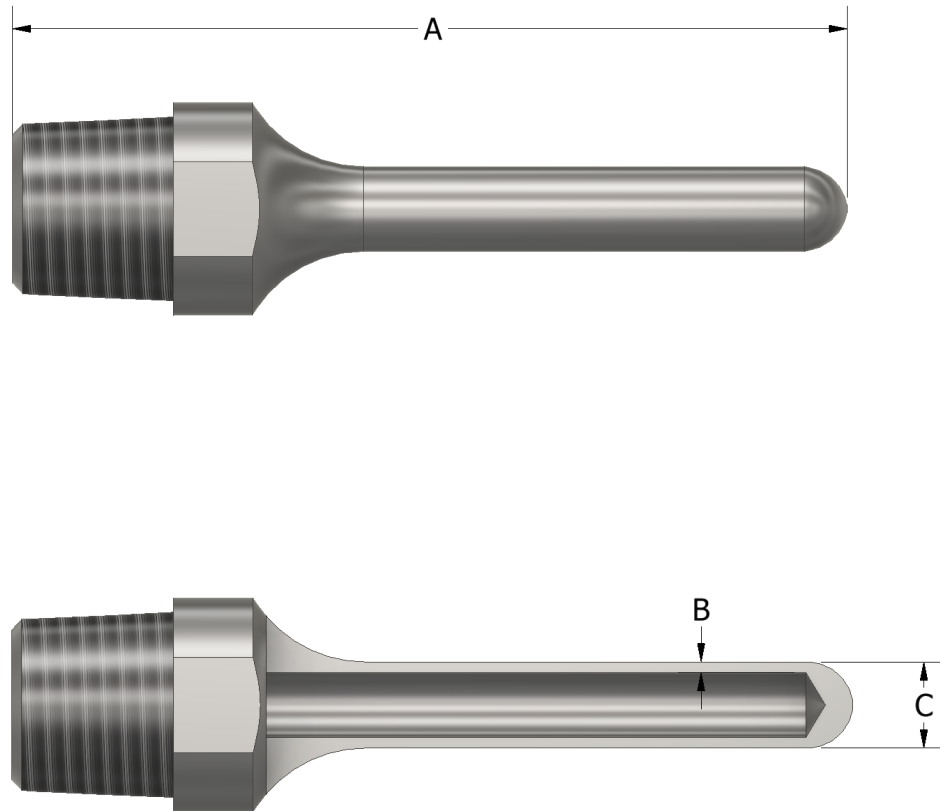

SAND PROBE

PHONE: 504-340-0055
FAX: 504-340-0056
EMAIL: SALES@RUELCO.COM

1209 DISTRIBUTORS ROW
NEW ORLEANS, LA 70123

DIMENSIONS

PIPE SIZE	2 INCH	3 INCH	4 INCH	5 INCH	6 INCH
A	1.875" (47.6 mm)	2.437" (61.9 mm)	2.937" (74.6 mm)	3.937" (100 mm)	4.437" (112.7 mm)

DIMENSIONS

PIPE SCHEDULE	SCH. 40	SCH. 80	SCH. 160	.065 WALL	SCH. XXH
B	.025" (.64 mm)	.032" (.81 mm)	.050" (1.3 mm)	.065" (1.65mm)	.125" (3.2 mm)
C	.25" (6.4 mm)	.25" (6.4 mm)	.25" (6.4 mm)	.25" (6.4 mm)	.50" (12.7 mm)

SPECIFICATIONS

	2 INCH	3 INCH	4 INCH	5 INCH	6 INCH
316 ST. STL.	60 ft/s	40 ft/s	30 ft/s	22 ft/s	16 ft/s
1018 CARBON	50 ft/s	30 ft/s	25 ft/s	20 ft/s	15 ft/s

* MAX VELOCITY RECOMMENDATIONS ARE BASED UPON A STANDARD FLOW AND FLUID AND CAN VARY WITH OPERATING CONDITIONS

ORDERING CODE

1S-001-X X X

- 1 - Schedule 80 Probe Wall
- 2 - Schedule 160 Probe Wall
- 3 - Schedule XXH Probe Wall
- 4 - Schedule 40 Probe Wall
- 5 - .065" Probe Wall

- C - Carbon Steel Probe
- N - 316 St. Stl. Probe
- I - Inconel Probe
- S - Super Duplex Probe

- 2 - Probe for 2" Flowline
- 3 - Probe for 3" Flowline
- 4 - Probe for 4" Flowline
- 5 - Probe for 5" Flowline
- 6 - Probe for 6" Flowline

PHONE: 504-340-0055
 FAX: 504-340-0056
 EMAIL: SALES@RUELCO.COM

1209 DISTRIBUTORS ROW
 NEW ORLEANS, LA 70123

SAND PROBE

OPERATION

The Ruelco High Velocity Sand Probe is designed to work with the Ruelco Sand Probe Relay to provide a positive indication of excessive erosion or corrosion which can occur in high flow line pipes due to sand or other foreign debris. The thin wall probe will wear due to the constant presence of sand and activate the relay once pressure integrity has been lost. This will alert field personnel to possible inspection and repair needs. The probe is designed to wear 5 times faster than the flow line it is protecting and is pressure rated to 1.25 times the pipe it is installed into.

FEATURES

- Stock probes available in 316 stainless steel and 1018 carbon steel
- Exotic Materials available
- Temperature Range -50°F to 450°F
- Custom wall thicknesses available

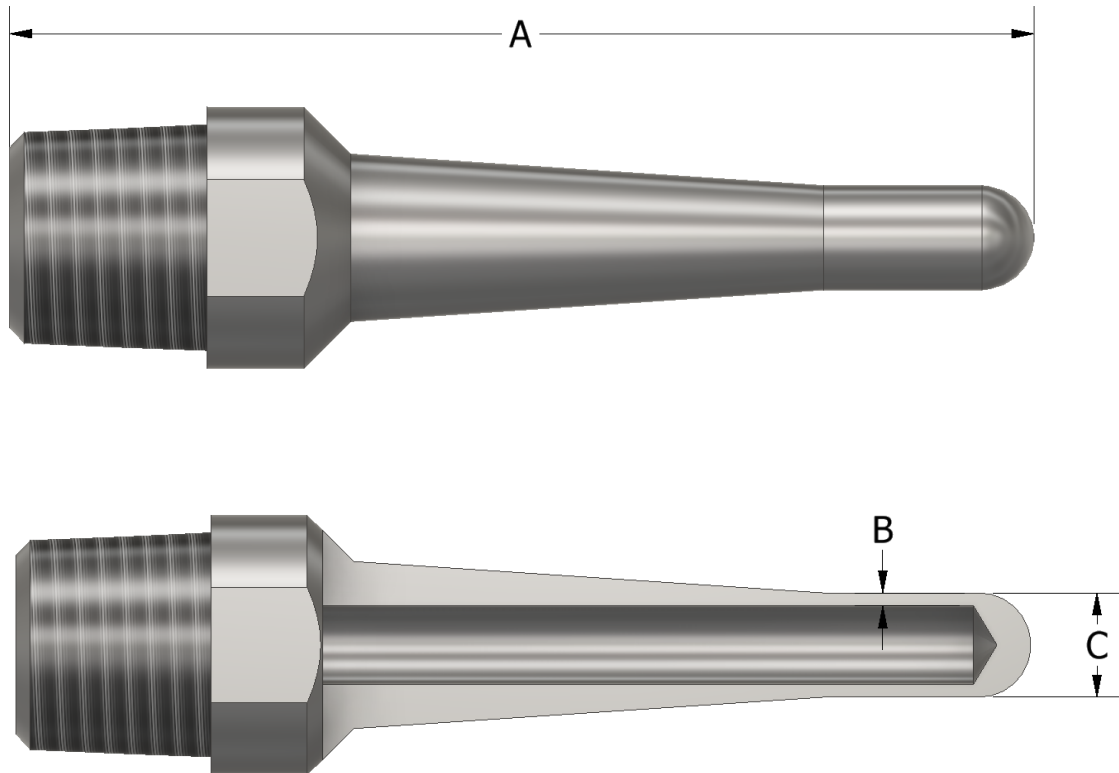

HIGH VELOCITY SAND PROBE

PHONE: 504-340-0055
FAX: 504-340-0056
EMAIL: SALES@RUELCO.COM

1209 DISTRIBUTORS ROW
NEW ORLEANS, LA 70123

DIMENSIONS

PIPE SIZE	2 INCH	3 INCH	4 INCH	5 INCH	6 INCH
A	1.875" (47.6 mm)	2.437" (61.9 mm)	2.937" (74.6 mm)	3.937" (100 mm)	4.437" (112.7 mm)

DIMENSIONS

PIPE SCHEDULE	SCH. 40	SCH. 80	SCH. 160	.065 WALL	SCH. XXH
B	.025" (.64 mm)	.032" (.81 mm)	.050" (1.3 mm)	.065" (1.65mm)	.125" (3.2 mm)
C	.25" (6.4 mm)	.25" (6.4 mm)	.25" (6.4 mm)	.25" (6.4 mm)	.50" (12.7 mm)

SPECIFICATIONS (MAXIMUM VELOCITY)

	2 INCH	3 INCH	4 INCH	5 INCH	6 INCH
316 ST. STL.	100 ft/s	65 ft/s	45 ft/s	32 ft/s	25 ft/s
1018 CARBON	70 ft/s	45 ft/s	35 ft/s	25 ft/s	20 ft/s

* MAX VELOCITY RECOMMENDATIONS ARE BASED UPON A STANDARD FLOW AND FLUID AND CAN VARY WITH OPERATING CONDITIONS

ORDERING CODE

1S-H01-X X X

- 1 - Schedule 80 Probe Wall
- 2 - Schedule 160 Probe Wall
- 3 - Schedule XXH Probe Wall
- 4 - Schedule 40 Probe Wall
- 5 - .065" Probe Wall

- C - Carbon Steel Probe
- N - 316 St. Stl. Probe
- I - Inconel Probe
- S - Super Duplex Probe

- 2 - Probe for 2" Flowline
- 3 - Probe for 3" Flowline
- 4 - Probe for 4" Flowline
- 5 - Probe for 5" Flowline
- 6 - Probe for 6" Flowline

PHONE: 504-340-0055
 FAX: 504-340-0056
 EMAIL: SALES@RUELCO.COM

1209 DISTRIBUTORS ROW
 NEW ORLEANS, LA 70123

OPERATION

The Ruelco High Pressure Sand Probe is designed to work with the Ruelco 15,000 psi Sand Probe Relay to provide a positive indication of excessive erosion or corrosion which can occur in flow line pipes due to sand or other foreign debris. The thin wall probe will wear due to the constant presence of sand and activate the relay once pressure integrity has been lost. This will alert field personnel to possible inspection and repair needs. The probe is designed to wear 5 times faster than the flow line it is protecting and is pressure rated to 1.25 times the pipe it is installed into.

FEATURES

- Stock probes available in 316 stainless steel and 1018 carbon steel
- Exotic Materials available
- Temperature Range -50°F to 450°F
- Custom wall thicknesses available

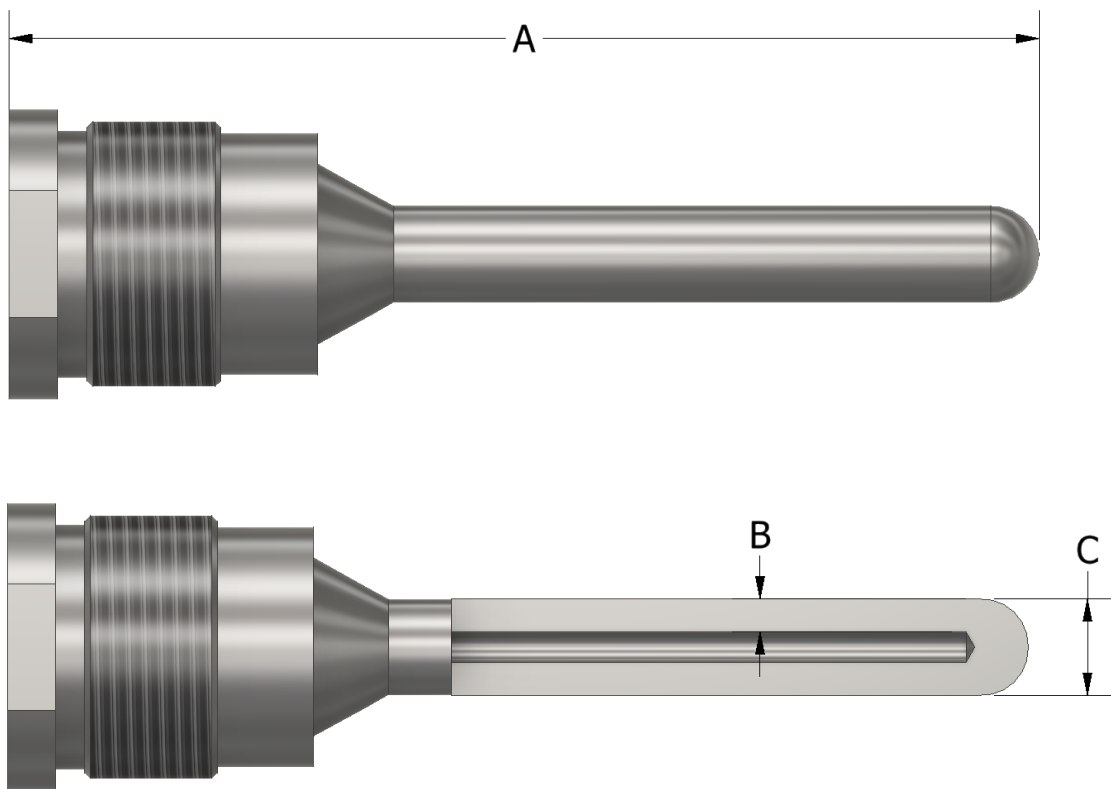

HIGH PRESSURE SAND PROBE

PHONE: 504-340-0055
FAX: 504-340-0056
EMAIL: SALES@RUELCO.COM

1209 DISTRIBUTORS ROW
NEW ORLEANS, LA 70123

DIMENSIONS

PIPE SIZE	2 INCH	3 INCH	4 INCH
A	4.75" (120.6 mm)	5.31" (134.9 mm)	5.81" (147.6 mm)
B	.172" (4.37 mm)	.172" (4.37 mm)	.172" (4.37 mm)
C	.500" (12.7 mm)	.500" (12.7 mm)	.500" (12.7 mm)

SPECIFICATIONS

MAXIMUM WORKING PRESSURE	15,000 PSI (1035 BAR)
AMBIENT TEMPERATURE RANGE	-50° TO 450° F -45° TO 232° C

ORDERING CODE

1S-010-6 X X

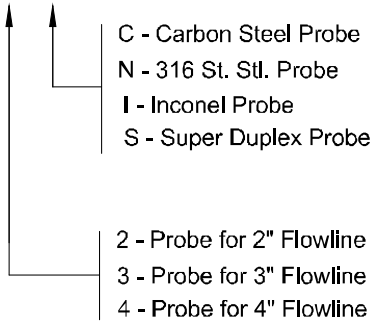

PHONE: 504-340-0055
 FAX: 504-340-0056
 EMAIL: SALES@RUELCO.COM

1209 DISTRIBUTORS ROW
 NEW ORLEANS, LA 70123