

OPERATION

The Ruelco Model 38C2 is a liquid level switch designed to meet the growing industry demand for durable, easy to maintain and accurate, electrical discreet point liquid level indication. Its non-externally adjustable set point makes it ideal for safety level switches and redundant back-up switches. It can provide control for simple local systems up to the most sophisticated process control systems. The direct action of the flex level design ensures trouble free operation in the process fluids with specific gravities as low as 0.6 without any fine tuning or other adjustments.

FEATURES

- 316 stainless steel construction (models to N.A.C.E. MR0175 available)
- Design has no deep cavities or recesses exposed to the process fluids for debris accumulation and is excellent for dirty fluid applications
- Uses a patented pivot seal mechanism to transmit liquid buoyancy to the valve operation mechanism with the pivot completely isolated from the process fluid
- Uses hermetically sealed, snap acting dry contact, explosion proof switch U.L. rated
- Level adjustments cannot be easily tampered with after installation, making this switch well suited for critical applications

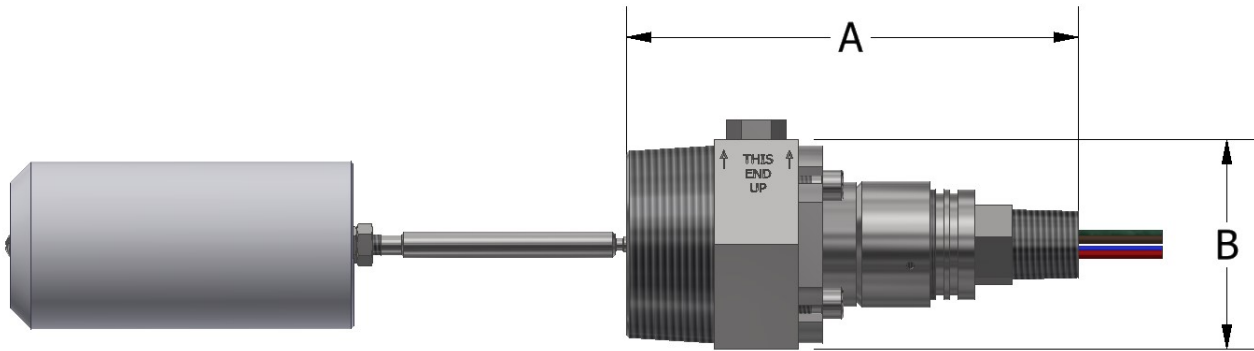

DIMENSIONS

A	5.44" (138.2 mm)
B	2.50" HEX (63.5 mm)
ELECTRICAL CONNECTION	1/2" MNPT
ELECTRICAL LEADS	18" (457.2 mm)
WEIGHT	3.8 LBS (1.7 kg)

SPECIFICATIONS

MAXIMUM WORKING PRESSURE	2,160 PSI (149 BAR)
AMBIENT TEMPERATURE RANGE	-20 TO 158° F -29 TO 70° C
MINIMUM SPECIFIC GRAVITY	0.6

PHONE: 504-340-0055
 FAX: 504-340-0056
 EMAIL: SALES@RUELCO.COM

1209 DISTRIBUTORS ROW
 NEW ORLEANS, LA 70123

ELECTRICAL OPERATION

LEAD	COLOR	RISING LEVEL	FALLING LEVEL
NO / NO2	BLUE / PURPLE	CLOSES	OPENS
NC / NC2	RED / BLACK	OPENS	CLOSES
C / C2	BROWN / YELLOW	COMMON LEADS	
GND	GREEN	GROUND	

ELECTRICAL SPECIFICATIONS

SPDT & DPDT SWITCH MAXIMUM VOLTAGE	250 VAC 28 VDC
SPDT & DPDT SWITCH AMPS @ MAXIMUM VOLTAGE	5 AMPS
AMBIENT TEMPERATURE RANGE	-20 TO 158° F

ELECTRICAL CERTIFICATIONS

UNDERWRITERS LABORATORIES	CLASS I, GROUPS A,B,C,D
UNDERWRITERS LABORATORIES	CLASS II, GROUPS E,F,G
ATEX	Ex d IIC

ELECTRIC 2" NPT LEVEL SWITCH

PHONE: 504-340-0055
 FAX: 504-340-0056
 EMAIL: SALES@RUELCO.COM

1209 DISTRIBUTORS ROW
 NEW ORLEANS, LA 70123

PARTS LIST

ITEM	QUANTITY	DESCRIPTION	MATERIAL
1	1	DISPLACER ASSEMBLY	POLYPROPYLENE OR 316 ST. STL.
2	1	FLOAT ROD	316 ST. STL.
3	1	BODY SEAL RETAINER	316 ST. STL.
4*	1	BODY SEAL	FLUOROCARBON
5	1	BODY	316 ST. STL.
6	1	SPRING CAP	316 ST. STL.
7	1	SPRING	INCONEL
8	1	SPRING GUIDE	316 ST. STL.
9	4	SOCKET HEAD CAP SCREW	316 ST. STL.
10	1	ELECTRIC VALVE BODY	CF-8M
11*	2	WEAR BANDS	DELTRIN
12	1	ELECTRIC POPPET	316 ST. STL.
13*	1	REMOVABLE PIVOT	17-4 PH ST. STL.
14	1	CONE	17-4 PH ST. STL.
15	1	FLOAT ROD NUT	316 ST. STL.
16	1	PUSH ROD ASSEMBLY	316 ST. STL.
17A	1	SPDT SWITCH	316 ST. STL.
17B	-	DPDT SWITCH	316 ST. STL.

* INDICATES ITEMS IN THE REPAIR KIT

REPAIR KIT

- 38-016-000

OTHER TEMPERATURE RANGES AND SEAL COMPOUNDS AVAILABLE UPON REQUEST

ORDERING CODE

BODY CODE: 38C2

PHONE: 504-340-0055
 FAX: 504-340-0056
 EMAIL: SALES@RUELCO.COM

1209 DISTRIBUTORS ROW
 NEW ORLEANS, LA 70123

OPERATION

The Ruelco Model 39C2 is a liquid level switch designed to meet the growing industry demand for durable, easy to maintain and accurate, electrical discreet point liquid level indication. Its non-externally adjustable set point makes it ideal for safety level switches and redundant back-up switches. It can provide control for simple local systems up to the most sophisticated process control systems. The direct action of the flex level design ensures trouble free operation in the process fluids with specific gravities as low as 0.6 without any fine tuning or other adjustments.

FEATURES

- 316 stainless steel construction (models to N.A.C.E. MR0175 available)
- Design has no deep cavities or recesses exposed to the process fluids for debris accumulation and is excellent for dirty fluid applications
- Uses a patented pivot seal mechanism to transmit liquid buoyancy to the valve operation mechanism with the pivot completely isolated from the process fluid
- Uses hermetically sealed, snap acting dry contact, explosion proof switch U.L. rated
- Level adjustments cannot be easily tampered with after installation, making this switch well suited for critical applications

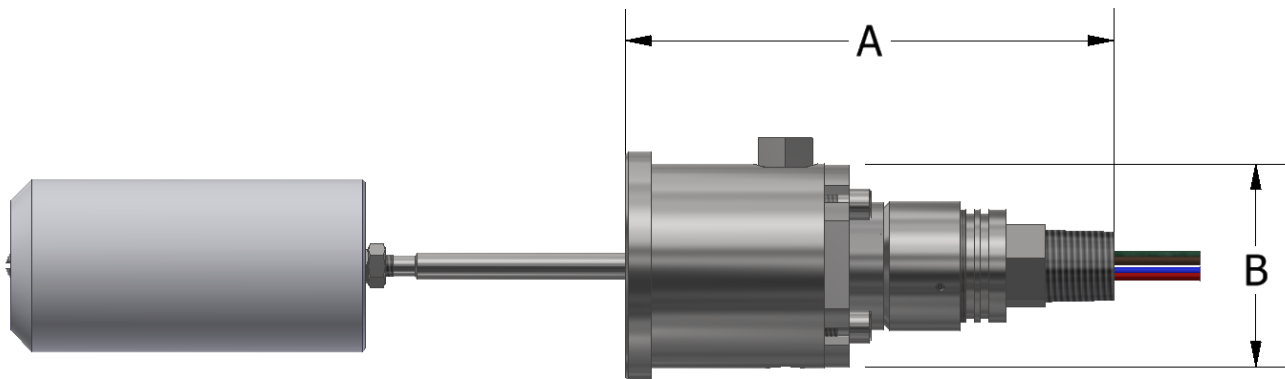

DIMENSIONS

A	5.72" (145.3 mm)
B	2.37" (60.2 mm)
ELECTRICAL CONNECTION	1/2" MNPT
ELECTRICAL LEADS	18" (457.2 mm)
WEIGHT	3.8 LBS (1.7 kg)

SPECIFICATIONS

MAXIMUM WORKING PRESSURE	2,160 PSI (149 BAR)
AMBIENT TEMPERATURE RANGE	-20 TO 158° F -29 TO 70° C
MINIMUM SPECIFIC GRAVITY	0.6

PHONE: 504-340-0055
 FAX: 504-340-0056
 EMAIL: SALES@RUELCO.COM

1209 DISTRIBUTORS ROW
 NEW ORLEANS, LA 70123

ELECTRICAL OPERATION

LEAD	COLOR	RISING LEVEL	FALLING LEVEL
NO / NO2	BLUE / PURPLE	CLOSES	OPENS
NC / NC2	RED / BLACK	OPENS	CLOSES
C / C2	BROWN / YELLOW	COMMON LEADS	
GND	GREEN	GROUND	

ELECTRICAL SPECIFICATIONS

SPDT & DPDT SWITCH MAXIMUM VOLTAGE	250 VAC 28 VDC
SPDT & DPDT SWITCH AMPS @ MAXIMUM VOLTAGE	5 AMPS
AMBIENT TEMPERATURE RANGE	-20 TO 158° F

ELECTRICAL CERTIFICATIONS

UNDERWRITERS LABORATORIES	CLASS I, GROUPS A,B,C,D
UNDERWRITERS LABORATORIES	CLASS II, GROUPS E,F,G
ATEX	Ex d IIC

ELECTRIC FLANGE LEVEL SWITCH

PHONE: 504-340-0055
 FAX: 504-340-0056
 EMAIL: SALES@RUELCO.COM

1209 DISTRIBUTORS ROW
 NEW ORLEANS, LA 70123

PARTS LIST

ITEM	QUANTITY	DESCRIPTION	MATERIAL
1	1	DISPLACER ASSEMBLY	POLYPROPYLENE OR 316 ST. STL.
2	1	FLOAT ROD	316 ST. STL.
3	1	BODY SEAL RETAINER	316 ST. STL.
4*	1	BODY SEAL	FLUOROCARBON
5	1	FLANGE BODY	316 ST. STL.
6	1	SPRING CAP	316 ST. STL.
7	1	SPRING	INCONEL
8	1	SPRING GUIDE	316 ST. STL.
9	4	SOCKET HEAD CAP SCREW	316 ST. STL.
10	1	ELECTRIC VALVE BODY	CF-8M
11*	2	WEAR BANDS	DELTRIN
12	1	ELECTRIC POPPET	316 ST. STL.
13*	1	REMOVABLE PIVOT	17-4 PH ST. STL.
14	1	CONE	17-4 PH ST. STL.
15	1	FLOAT ROD NUT	316 ST. STL.
16	1	PUSH ROD ASSEMBLY	316 ST. STL.
17A	1	SPDT SWITCH	316 ST. STL.
17B	-	DPDT SWITCH	316 ST. STL.

* INDICATES ITEMS IN THE REPAIR KIT

REPAIR KIT

- 38-016-000

OTHER TEMPERATURE RANGES AND SEAL COMPOUNDS AVAILABLE UPON REQUEST

ORDERING CODE

BODY CODE: 39C2

PHONE: 504-340-0055
 FAX: 504-340-0056
 EMAIL: SALES@RUELCO.COM

1209 DISTRIBUTORS ROW
 NEW ORLEANS, LA 70123

POLYPROPYLENE 3" ROD

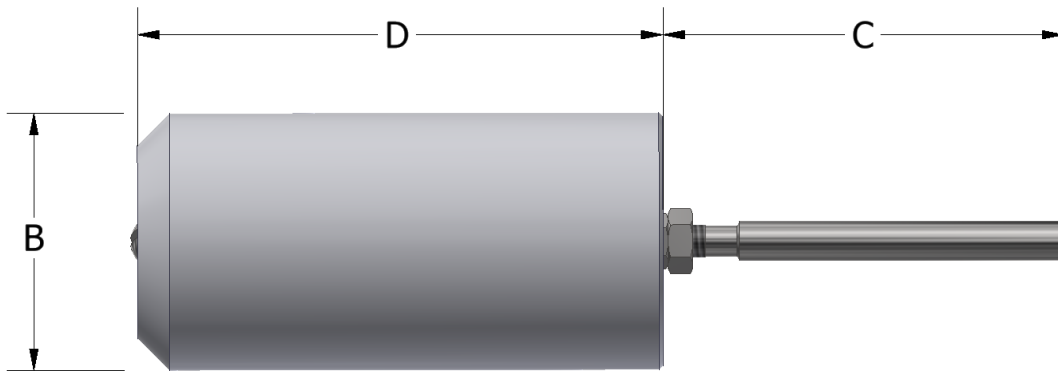

DIMENSIONS

B	2.00" (50.8 mm)
C	3.25" (82.6 mm)
D	4.10" (104.14 mm)

SPECIFICATIONS

MAXIMUM WORKING PRESSURE	2,160 PSI (149 BAR)
AMBIENT TEMPERATURE RANGE	-20 TO 250° F -29 TO 122° C
MAXIMUM PROCESS TEMPERATURE	200°F (93°C)

DISPLACERS

ORDERING CODE

(BODY CODE) X P X E 30

Standard Corrosive Service -- (-) |
 N.A.C.E. option ---N |
 SPDT Electric Switch -- S |
 DPDT Electric Switch -- D |

PHONE: 504-340-0055
 FAX: 504-340-0056
 EMAIL: SALES@RUELCO.COM

1209 DISTRIBUTORS ROW
 NEW ORLEANS, LA 70123

POLYPROPYLENE 6" ROD

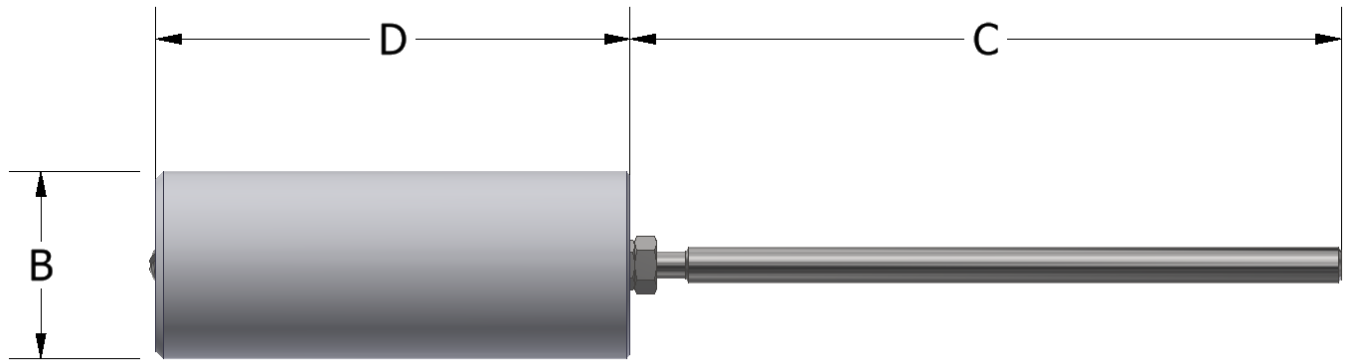

DIMENSIONS

B	1.62" (41.3 mm)
C	6.50" (165.1 mm)
D	4.10" (104.14 mm)

SPECIFICATIONS

MAXIMUM WORKING PRESSURE	2,160 PSI (149 BAR)
AMBIENT TEMPERATURE RANGE	-20 TO 250° F -29 TO 122° C
MAXIMUM PROCESS TEMPERATURE	200°F (93°C)

ORDERING CODE

(BODY CODE) X P X E 60

Standard Corrosive Service -- (-)

N.A.C.E. option ---N

SPDT Electric Switch -- S

DPDT Electric Switch -- D

PHONE: 504-340-0055
 FAX: 504-340-0056
 EMAIL: SALES@RUELCO.COM

1209 DISTRIBUTORS ROW
 NEW ORLEANS, LA 70123

DISPLACERS

POLYPROPYLENE 10' HANGDOWN

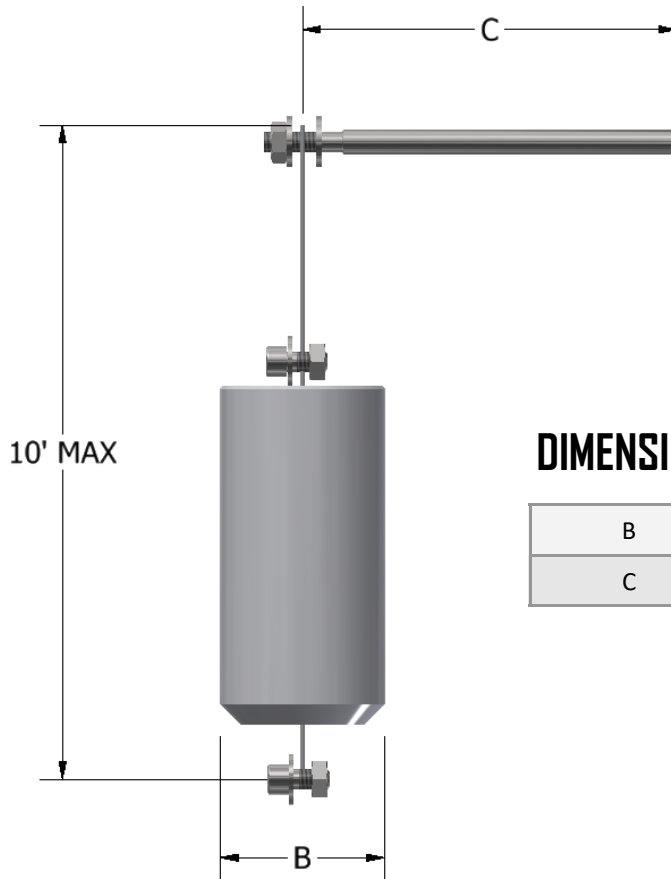

DIMENSIONS

B	2.00" (50.8 mm)
C	4.50" (114.3 mm)

SPECIFICATIONS

MAXIMUM WORKING PRESSURE	2,160 PSI (149 BAR)
AMBIENT TEMPERATURE RANGE	-20 TO 250° F -29 TO 122° C
MAXIMUM PROCESS TEMPERATURE	200° F (93°C)

ORDERING CODE

(BODY CODE) X P X E 33

Standard Corrosive Service -- (-)

N.A.C.E. option ---N

SPDT Electric Switch -- S

DPDT Electric Switch -- D

PHONE: 504-340-0055
FAX: 504-340-0056
EMAIL: SALES@RUELCO.COM

1209 DISTRIBUTORS
ROW
NEW ORLEANS, LA 70123

DISPLACERS

POLYPROPYLENE EXTENDED ROD



DIMENSIONS

	8" ROD	10" ROD	12" ROD	14" ROD
B	1.62" (41.3 mm)	1.62" (41.3 mm)	1.62" (41.3 mm)	1.50" (38.1 mm)
C	6.72" (170.7 mm)	9.95" (252.7 mm)	12.19" (309.6 mm)	13.75" (349.3 mm)
D	3.00" (76.2 mm)	2.55" (64.8 mm)	2.12" (53.8 mm)	2.30" (58.4 mm)

SPECIFICATIONS

MAXIMUM WORKING PRESSURE	2,160 PSI (149 BAR)
AMBIENT TEMPERATURE RANGE	-20 TO 250° F -29 TO 122° C
MAXIMUM PROCESS TEMPERATURE	200°F (93°C)

ORDERING CODE

(BODY CODE) X P X E X O

Standard Corrosive Service -- (-) | | | | |
 N.A.C.E. option ---N | | | | |

SPDT Electric Switch -- S | | | | |
 DPDT Electric Switch -- D | | | | |

8 -- 8" ROD
 A -- 10" ROD
 C -- 12" ROD
 E -- 14" ROD

DISPLACERS

PHONE: 504-340-0055
 FAX: 504-340-0056
 EMAIL: SALES@RUELCO.COM

1209 DISTRIBUTORS ROW
 NEW ORLEANS, LA 70123

316 ST. STL. 3" ROD

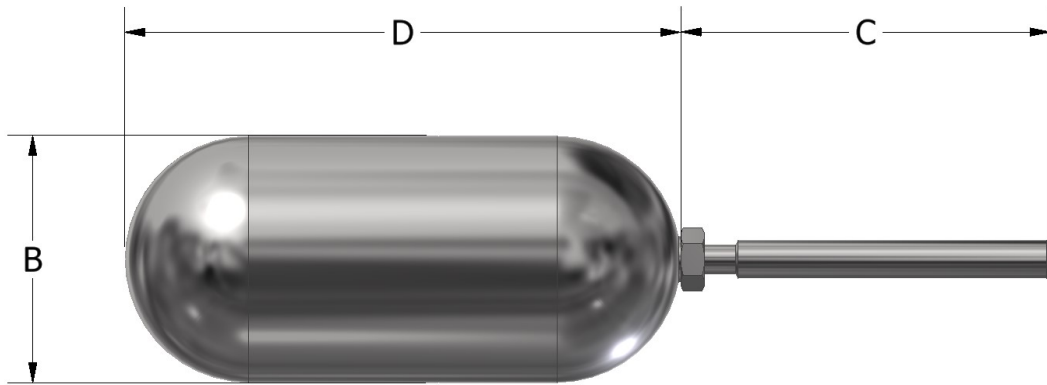

DIMENSIONS

B	2.00" (50.8 mm)
C	3.25" (82.6 mm)
D	4.50" (114.3 mm)

SPECIFICATIONS

MAXIMUM WORKING PRESSURE	2,160 PSI (149 BAR)
AMBIENT TEMPERATURE RANGE	-20 TO 300° F -29 TO 148° C
MAXIMUM PROCESS TEMPERATURE	300°F (148°C)

ORDERING CODE

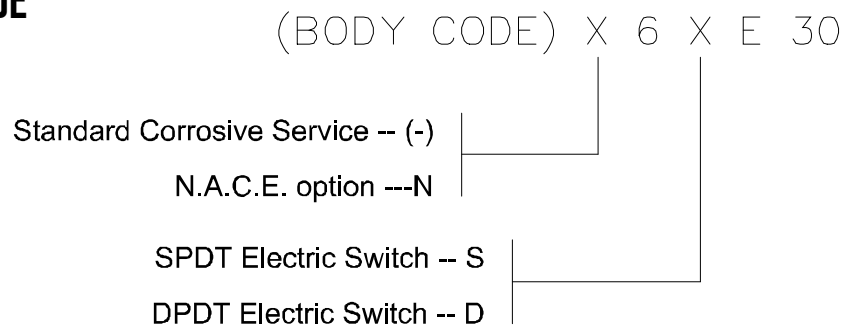

PHONE: 504-340-0055
 FAX: 504-340-0056
 EMAIL: SALES@RUELCO.COM

1209 DISTRIBUTORS ROW
 NEW ORLEANS, LA 70123

DISPLACERS

316 ST. STL. 6" ROD

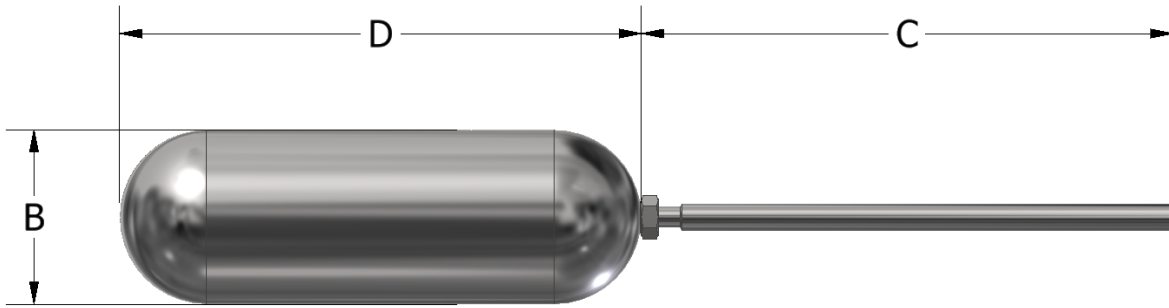

DIMENSIONS

B	2.00" (50.8 mm)
C	6.50" (165.1 mm)
D	6.00" (152.4 mm)

SPECIFICATIONS

MAXIMUM WORKING PRESSURE	300 PSI (20.68 BAR)
AMBIENT TEMPERATURE RANGE	-20 TO 300° F
	-29 TO 148° C
MAXIMUM PROCESS TEMPERATURE	300°F (148°C)

ORDERING CODE

(BODY CODE) SA0002 X X E60

Standard Corrosive Service -- (-)

N.A.C.E. option ---N

SPDT Electric Switch -- S

DPDT Electric Switch -- D

PHONE: 504-340-0055
 FAX: 504-340-0056
 EMAIL: SALES@RUELCO.COM

1209 DISTRIBUTORS ROW
 NEW ORLEANS, LA 70123

DISPLACERS