

## 1.0 INTRODUCTION

The Ruelco **Model 30C2** (2" NPT Mount)/**31C2** (Flange Mount) 3-way pneumatic liquid level switch is typically mounted directly into a tank or vessel or in an optional external cage (See Figures 1,2). Horizontal or hang down displacer elements are available.

This displacer operates a pneumatic valve when a liquid in a tank or a pressurized vessel reaches a predetermined level. The operation mode, as a high or a low level sensor, is selected by rotating the valve body 180 degrees.

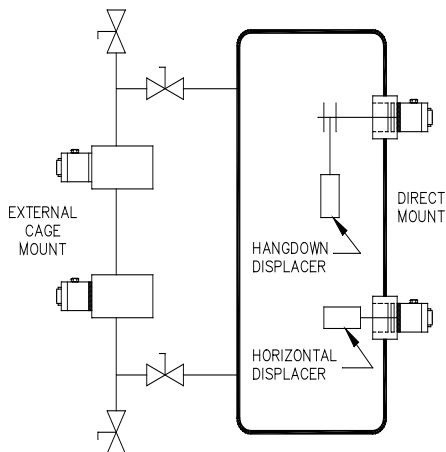

**FIG. 1**  
TYPICAL MOUNTING OF MODEL 30C2  
LEVEL SWITCHES

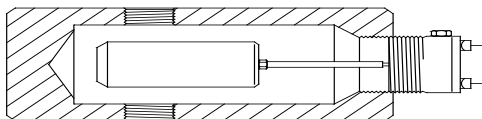

**FIG. 2**  
MODEL 30C2 SHOWN IN  
MODEL 3C01 EXTERNAL CAGE

## 2.0 OPERATION (See Fig. 3)

When in the non-tripped condition, the 3-way pneumatic valve is configured as a normally open valve when set for high level detection and as a normally closed valve when set for low level detection.

When used as a high level sensor, the valve will allow air flow from inlet to outlet when the liquid is below the displacer. When liquid contacts the displacer, the valve will block the inlet pressure and vent the outlet pressure.

When used as a low level sensor, the valve will allow air flow from inlet to outlet when the liquid is above the displacer. When liquid no longer contacts the displacer, the valve will block the inlet pressure and vent the outlet pressure.

Because of the balanced design of the valve, variations in instrument pressure from 5 to 50 PSI will have little effect on level switch performance.

The switch senses a change in the buoyancy of a displacer assembly inside a pressurized or unpressurized vessel. To transmit the buoyancy change, a pivoting action is used. The I.D. of the cone contacts the pivot attached to the push rod and valve body. The o-ring (provides a pressure tight seal between the body and the shaft of the cone protruding through the o-ring. Pressure in the vessel, if any, acting on the shaft of the cone, forces the cone against the pivot point on the valve body. The position of this point, at the center of the o-ring, allows the displacer assembly to move up or down.

## 2.1 HIGH LEVEL OPERATION (NORMALLY OPEN)

As the liquid level rises and begins to cover the displacer assembly, the buoyancy in the liquid reduces the counterclockwise rotational force on the cone. At some point, the spring will exert a greater clockwise rotational force and cause the cone to push the valve stem downward, and act on the push rod and 3-way valve. This allows the pressure present at the outlet to vent through the weep holes in the valve body while blocking the inlet pressure.

## 2.2 LOW LEVEL OPERATION (NORMALLY CLOSED)

As the liquid level falls and begins to uncover the displacer assembly, its buoyancy in the liquid increases the counterclockwise rotational force on the cone. At some point, the displacer will exert a greater clockwise rotational force and cause the cone to push the valve stem upward, and act on the push rod and 3-way valve. This allows the pressure present at the outlet to vent through the weep holes in the valve body while blocking the inlet pressure.

**NOTE: THE VALVE CAN BE USED WITH OPPOSITE FUNCTION IF ROTATED 180 DEG.**

## 3.0 INSTALLATION

### 3.1 EXTERNAL CAGE TO VESSEL

It is suggested that the level switch be installed in an external cage for maintenance and testing purposes. One recommended piping system for mounting an external cage to a vessel is shown in *Figure 1*. The valves above and below the cage are required for testing and maintenance purposes.

If a cage with butt weld connections is used, the level switch should be removed from the cage before welding. This will prevent weld sparks from damaging the displacer assembly. Remove the switch from the cage as per instructions in *Paragraphs 5.2.1 through 5.2.2 of the FULL DISASSEMBLY* section of this manual. After welding, install the level switch as per instructions in *Section 3.2, INSTALLING LEVEL SWITCH IN CAGE*.

If the cage has threaded or flanged process connections, the level switch does not have to be removed before mounting the switch to the vessel. Cages with 1" NPT process connections may be installed on the vessel with 1", 3/4" or 1/2" O.D. piping.

**CAUTION: Be sure the pressure rating of all valves, pipe and pipe fittings meets or exceeds the working pressure of the vessel on which they are to be installed. Adequate support for long pipe runs should be provided to prevent excessive vibrations of the level switch.**

It is recommended that external cages be installed with the process connections as close to vertical and the cage length as close to horizontal as possible. This will insure the proper liquid flow into and out of the cage.

### 3.2 LEVEL SWITCH INSTALLATION

Before installing a level switch into an external cage or mating flange, verify that level switch is set up or the operation required (i.e., high or low liquid level detection). See *Section 4.0, CHANGING MODE OF OPERATION* and *Figure 5*. **NOTE:** When direct mounting a level switch to a tank or vessel, verify that the end displacer assembly will be at least 1/2" (13mm)

longer than the 2" connection on which it is being installed. (See Figure 4).

**TOOLS REQUIRED:** A 2.125" open end wrench or a suitable adjustable wrench or pipe wrench.

- 3.2.1 Clean any dirt or debris from the 2" NPT pipe threads and the external cage (if any are being utilized).
- 3.2.2 Apply Teflon tape or other thread sealing compound to the 2" NPT threads on the level switch.

3.2.3 Apply an anti-galling compound to the 2" NPT female thread into which the switch is installed.

3.2.4 Screw the level switch into the mounting thread and tighten with the wrench. When tight the spring cap must be up as shown in Fig. 5.

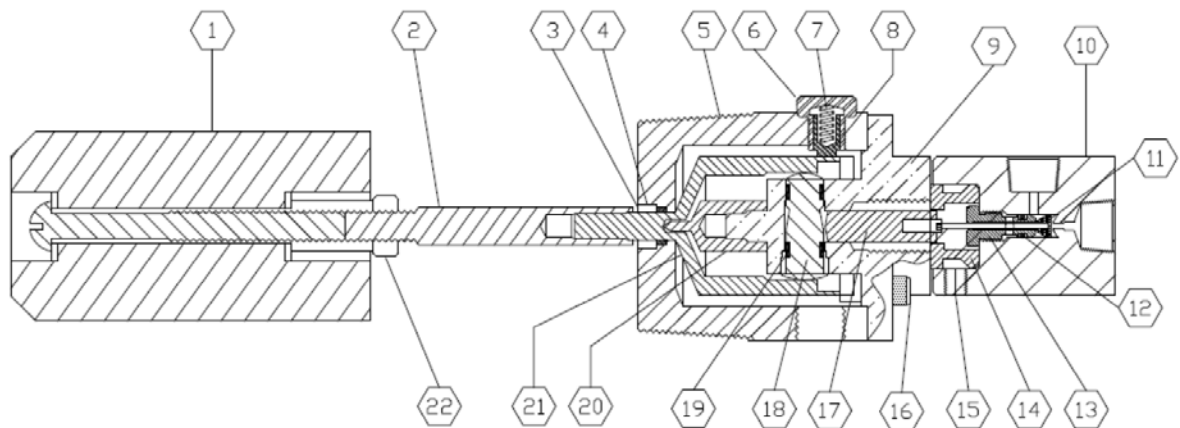
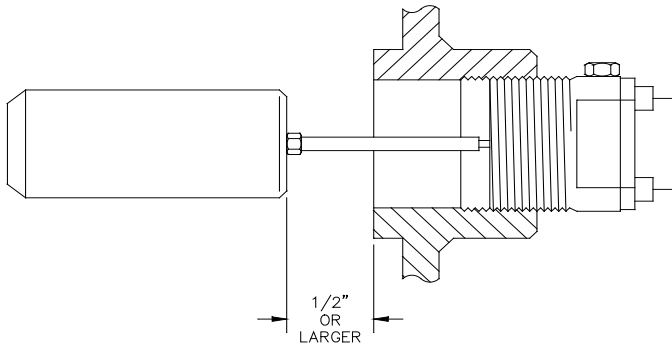

FIG. 3

**CAUTION:** If using a pipe wrench, do not allow the wrench jaws to contact the spring cap. Wrench forces may damage the cap and prevent the switch from operating properly.

**NOTE:** THE SPRING CAP MUST ALWAYS BE IN THE VERTICAL POSITION AS SHOWN IN FIG. 5 FOR THE “FLEX LEVEL” SWITCH TO OPERATE PROPERLY.

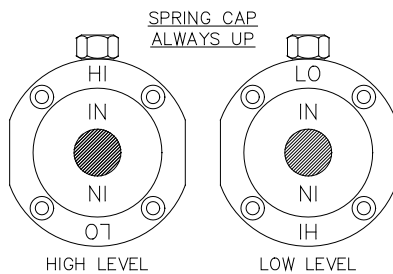

**FIG. 4**  
TYPICAL DIRECT MOUNTING

#### 4.0 CHANGING MODE OF OPERATION

TOOLS REQUIRED: 3/16” Allen Wrench

The level switch can be changed from high level detection to low level detection very easily. If the level switch is installed into a pressurized cage or vessel, the pressure does not have to be removed, but the caution in Section 4.2 should be followed closely. Fig. 5 shows the proper orientation of the level switch function markings for high and low level operation.



**FIG. 5**

#### 4.1 UNPRESSURIZED CAGE OR VESSEL

- 4.1.1 Verify that no pressure is present in the cage or vessel. If this cannot be verified, follow instructions in Section 4.2 PRESSURIZED CAGE OR VESSEL.
- 4.1.2 Block and bleed the instrument pressure from the inlet. Remove any instrument tubing connected to the inlet.
- 4.1.3 With the 3/16” Allen wrench, remove the four hex socket head cap screws. Rotate the valve body 180 degrees to change the mode of operation from high to low or from low to high as desired. See Fig. 5 for proper valve body orientation.
- 4.1.4 Replace the four hex socket cap screws and tighten.
- 4.1.5 Connect the instrument supply if it was disconnected.

#### 4.2 PRESSURIZED CAGE OR VESSEL

- 4.2.1 Block and bleed the instrument pressure from inlet. Remove any instrument tubing connected to the inlet.
- 4.2.2 Use a 3/16” Allen wrench and remove two of the hex socket head cap screws that are diagonally apart. Replace the two hex socket head cap screws just removed with two ¼”-20 screws or bolts that are 1-1/4’ to 1-1/2” long. These serve as a safety stop in the event the level switch has received unknown damage. Rotate the remaining two screws one turn at a time, alternating between the two. The process pressure acting on

the end of the cone that is protruding through the body will move the valve body outward as the two screws are turned. When the valve body has stopped moving, remove the four screws completely. Rotate the valve body 180 degrees to change the mode of operation from high to low or from low to high as desired. See *Fig. 5* for proper valve body orientation.

**CAUTION: THE VALVE BODY SHOULD MOVE OUTWARD 1/16" AND STOP AS THE DISPLACER ASSEMBLY CONTACTS THE BODY. IF THE PROCESS PRESSURE IS STILL EXERTING A FORCE ON THE VALVE BODY AFTER 1-1/2 TURNS, THEN STOP TURNING THE TWO SCREWS. THE UNIT MAY HAVE DAMAGE THAT WILL ALLOW THE CONE TO DISENGAGE THE O-RING AND THE PROCESS PRESSURE AND MEDIUM WILL ESCAPE THROUGH THE BODY. THE PROCESS PRESSURE WILL HAVE TO BE REMOVED FROM THE CAGE OR VESSEL BEFORE ANY FURTHER DISASSEMBLY IS POSSIBLE.**

4.2.3 Replace the four hex socket head cap screws and tighten.

4.2.4 Connect the instrument supply if it was disconnected.

## **5.0 DISASSEMBLY (SEE FIG. 1 and 3)**

### **TOOLS REQUIRED:**

7/16" open end wrench or adjustable wrench

5/8" open end wrench or adjustable wrench

3/16" Allen wrench

1/8" Allen wrench

Needle nose pliers

Pliers

O-ring pick or small screwdriver

Large adjustable wrench or pipe wrench

## **5.1 PARTIAL DISASSEMBLY (3-WAY POPPET VALVE REPAIR)**

**CAUTION: ONLY THE VALVE BODY CAN BE REMOVED FROM THE LEVEL SWITCH UNIT WITHOUT DEPRESSURIZING THE CAGE OR VESSEL. ANY FURTHER DISASSEMBLY WITH PRESSURE PRESENT ON THE CAGE OR VESSEL WILL RESULT IN SEVERE PERSONAL INJURY OR DAMAGE TO EQUIPMENT.**

5.1.1 It is not necessary to completely disassemble the unit to remove the valve body from the level switch. It is not required to depressurize the cage or the vessel the level switch is installed in, but it is recommended to do so if possible.

5.1.2 To remove the valve body when the level switch is installed in a pressurized cage or vessel, follow instructions in *Paragraph 5.1.3*. If the cage or vessel is not pressurized, use a 3/16" Allen wrench and remove the four hex socket head cap screws.

5.1.3 Use a 1/8" Allen wrench and loosen the three hex socket head set screws that are on the outside of the 3-way valve. This will allow for the removal of the 3-way valve from the level switch.

5.1.4 Note the orientation of the Push Rod and ensure this is not lost.

**CAUTION: THE VALVE BODY SHOULD MOVE OUTWARD 1/16" AND STOP AS THE DISPLACER ASSEMBLY CONTACTS THE BODY. IF THE PROCESS PRESSURE IS STILL EXERTING A FORCE ON THE VALVE BODY AFTER 1-1/2 TURNS, THEN STOP TURNING THE TWO SCREWS. THE UNIT MAY HAVE DAMAGE THAT WILL ALLOW THE CONE TO DISENGAGE THE O-RING (4) AND THE PROCESS PRESSURE AND MEDIUM WILL ESCAPE THROUGH THE BODY. THE PROCESS**

**PRESSURE WILL HAVE TO BE REMOVED FROM THE CAGE OR VESSEL BEFORE ANY FURTHER DISASSEMBLY IS POSSIBLE.**

- 5.1.5 Loosen the retainer and the stinger can be accessed.
- 5.1.6 The seals may be replaced as per instructions in the *Section 6.0 REPAIR and ASSEMBLY*.

**5.2 FULL DISASSEMBLY**

**CAUTION: ALL PRESSURE MUST BE REMOVED FROM THE CAGE OR VESSEL BEFORE FULL DISASSEMBLY CAN BE PERFORMED. FAILURE TO REMOVE THE PRESSURE MAY RESULT IN PERSONAL INJURY OR DAMAGE TO EQUIPMENT.**

- 5.2.1 Verify that all pressure has been removed from the cage or vessel and drain the liquid to a level below the level switch.
- 5.2.2 Using the large adjustable wrench or pipe wrench, remove the level switch from the cage or vessel.
- 5.2.3 Hold the float rod (2) with the pliers and rotate it counterclockwise to remove it from the level switch.
- 5.2.4 Normally it is not necessary to remove the displacer or float assembly from the float rod. If required, loosen the lock nut (18) and unthread the displacer or float assembly from the float rod.
- 5.2.5 Follow instructions in *Section 5.1 PARTIAL DISASSEMBLY* to remove and disassembly the valve body.
- 5.2.6 Use the 5/8" wrench and rotate the spring cap counterclockwise to remove it from the body. Care should be taken not to lose the spring and spring guide.

- 5.2.7 Using pliers to grip the O.D. of the pivot, rotate it counterclockwise to unthread it from the valve body.
- 5.2.8 Push the threaded end of the cone through the body.
- 5.2.9 Using an o-ring pick or small screwdriver, remove the o-ring from the body.

**6.0 REPAIR AND ASSEMBLY:  
REFER TO DATA SHEET FOR  
REPLACEMENT PART NUMBERS**

**TOOLS REQUIRED:**

- 7/16" open end wrench or adjustable wrench
- 5/8" open end wrench or adjustable wrench
- 3/16" Allen wrench
- Needle nose pliers
- Safety solvent
- Silicone based o-ring lubricant
- Large adjustable wrench or pipe wrench

- 6.1 Using appropriate safety solvent, clean all parts.
- 6.2 Inspect the I.D. of the valve retainer and the O.D. of the valve stem for nicks and gouges. Replace any worn or damaged parts.
- 6.3 The point of the pivot should not be flattened or bent. The sealing surfaces (side and bottom) for the seat o-ring should be free of pits and gouges. Replace if necessary.
- 6.4 If the level switch has a stainless steel displacer assembly, it should be free of dents, cracks or holes.
- 6.5 Lubricate all seals from the repair kit with a silicone-based lubricant.
- 6.6 Install the valve seat o-ring into the valve body and push it completely to the bottom of the receptacle.

- 6.7 Install the valve stem o-ring and the valve retainer o-ring. Lubricate the valve stem o-ring and insert the valve stem into the valve retainer.
- 6.8 Using the needle nose pliers, install the valve retainer with valve stem installed into the valve body and tighten.
- 6.9 Thread the pivot onto the valve body and firmly tighten with pliers.
- 6.10 Install the body o-ring into the body.
- 6.11 Lubricate the shaft and the threads on the threaded end of the cone. Install the cone into the body by turning clockwise and pushing gently.
- 6.12 Align the body tabs with the slots in the cone and slide the valve body into the level switch body.
- 6.13 Arrange the valve body in the correct position for the desired high or low operation. *See Fig. 5.* Install and tighten the four hex socket head cap screws.
- 6.14 Thread the float rod onto the cone and tighten securely with pliers. If the displacer assembly was removed, reinstall and tighten the lock nut securely.
- 6.15 Insert the spring and spring guide into the spring cap. Install the spring cap into the body and tighten.
- 6.16 Replace the level switch assembly into the cage or mating flange as per instructions in *Section 3 INSTALLATION.*

## 7.0 RECOMMENDED MAINTENANCE

PROCEDURE	INTERVAL
Test switch in place with Process liquids to check For proper operation.	every 30 days
Clean vent ports of debris	every 30 days
Replace body seal (4)	as required

## TROUBLESHOOTING

PROBLEM	PROBABLE CAUSE	RECOMMENDED ACTION
1) Level switch does not function	A) Debris blocking the vent port	Clean vent port and test switch
	B) Trash on inside of the cone (21).	Remove the valve body (9) per procedures in Section 5.1 and clean cone I.D.
	C) Poppet valve (18) sticking	Follow procedures in Sections 5.1 and 6.0 to disassemble and replace the seals (19)
	D) Inlet port plugged.	Disconnect all instrument tubing and clean inlet port. Clean instrumentation system filters.
	E) Connecting tubing plugged.	Remove and clean or replace instrument tubing. Clean instrumentation system filters.
	F) Trash accumulation on displacer assembly (1).	Remove switch from vessel or cage per procedures in Section 5.2
	G) "FLEX-LEVEL" not installed properly.	Use instructions given in Section 3.0 to properly install the switch.
2) Liquid or gas leakage from vent port.	A) Poppet valve seals (19) damaged or worn.	Follow procedures in Section 5.1 and 6.0 to disassemble and replace the seals (19).
	B) Body seal (4) damaged or worn	Replace body seal (4) per instructions in Section 5.0 and 6.0.

**CONSULT THE FACTORY OR AN AUTHORIZED DEALER IF THE SWITCH CANNOT BE REPAIRED BY FOLLOWING THESE PROCEDURES.**